

## Your beautiful water feature deserves elegant and energy efficient lighting by GTL Lighting.

Built to our exacting standards for long life and color accuracy, each fountain light from GTL undergoes rigorous underwater testing prior to installation. Our engineers provide mounts and color animations to enhance the quality of your unique installation, including special sequences to celebrate patriotic and religious holidays.

Our computer lighting controllers orchestrate the color and intensity of hundreds of lights with millisecond accuracy—and also integrate with landscape lighting, wall washes, and path lights to provide a cohesive outdoor experience for your tenants and guests. An internal calendar triggers lighting scenes based on date and time—automatically running special programs on holidays—while keeping track of sunrise and sunset for additional energy savings.

Sealed power supplies and actively cooled, weatherproof enclosures protect your investment from the extremes of the Gulf climate. Property engineering staff appreciates the flexibility of our designs, including the capability of integrating with existing building management systems and wired and wireless networks. We never play “hide the ball” with software in an attempt to lock clients into a relationship. Though we’re supremely confident in our start-up and programming services, we provide your staff with the piece-of-mind of a full suite of programming software and easy-to-use iPhone and Android applications.

As a local Houston business, we cherish our public spaces and enjoy them with our families. Therefore we monitor our installations as a matter of both good business and personal pride, supplying unmatched maintenance and after-installation care. Your facility’s public fountain is often the first architectural feature to greet your tenants and their clients. Make sure it is seen in the best light.

### Clamp Type



### Disk Base Type



#### ADDRESS

📍 9826 Clay Rd,  
Houston, TX 77080

#### CALL US

☎ 281.741.3116

#### EMAIL US

✉ info@gtlights.com

## Dimensions:

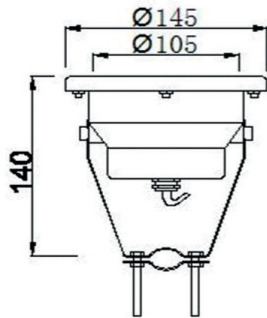

## Wiring:

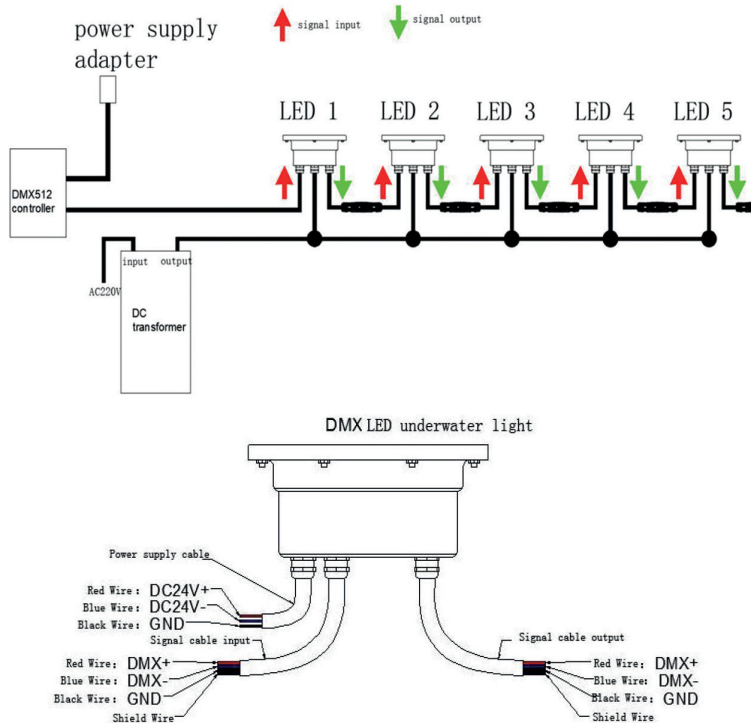

## Specifications:

- ✓ **Body construction:**  
304 stainless steel for excellent corrosion resistance
- ✓ **Lens:**  
5mm tempered glass
- ✓ **Power:**  
9W
- ✓ **Voltage:**  
24V DC
- ✓ **Color:**  
RGB
- ✓ **Control:**  
DMX512
- ✓ **Ingress Protection:**  
IP 68: suitable for continuous immersion
- ✓ **Certifications:**  
CE/ISO9001/IP68/RoHs
- ✓ **Beam Angle:**  
30° (10°/60°/90° available)
- ✓ **Operating temperature range:**  
-4°F to 113°F (-20°C to 45°C)
- ✓ **Maximum temperature range:**  
-40°F to 158°F (-40°C to 70°C)
- ✓ **LED life:**  
>50,000 hours
- ✓ **Mount:**  
Clamp and floor mounts available

## ADDRESS

📍 9826 Clay Rd,  
Houston, TX 77080

## CALL US

☎ 281.741.3116

## EMAIL US

✉ info@gtllights.com