

## Next Generation Landscape Lights

LED Strip from GTL Lighting makes architecture, landscaping, and fountains stylish and distinct at night. Flexible and waterproof, our strips outline facades and illuminate reflecting pools with a soft, unmistakable glow.

Our computer lighting controllers orchestrate the color and intensity of hundreds of lights with millisecond accuracy—and also integrate with landscape lighting, wall washes, and path lights to provide a cohesive outdoor experience for your tenants and guests. An internal calendar triggers lighting scenes based on date and time—automatically running special programs on holidays—while keeping track of sunrise and sunset for additional energy savings.

Sealed power supplies and actively cooled, weatherproof enclosures protect your investment from the extremes of the Gulf climate. Property engineering staff appreciates the flexibility of our designs, including the capability of integrating with existing building management systems and wired and wireless networks. We never play “hide the ball” with software in an attempt to lock clients into a relationship. Though we’re supremely confident in our start-up and programming services, we provide your staff with the piece-of-mind of a full suite of programming software and easy-to-use iPhone and Android applications.

As a local Houston business, we cherish our public spaces and enjoy them with our families. Therefore we monitor our installations as a matter of both good business and personal pride, supplying unmatched maintenance and after-installation care. Your facility’s public fountain is often the first architectural feature to greet your tenants and their clients. Make sure it is seen in the best light.

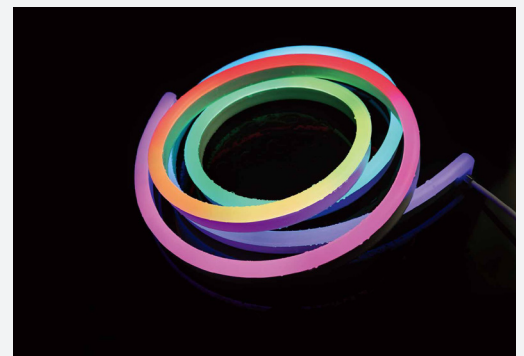
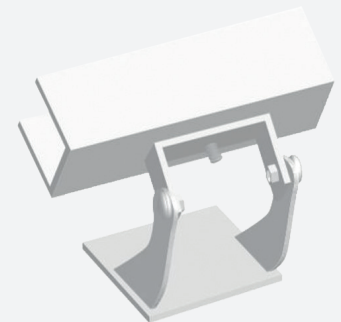
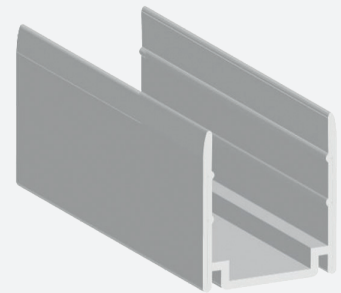

### ADDRESS

📍 9826 Clay Rd,  
Houston, TX 77080

### CALL US

☎ 281.741.3116

### EMAIL US

✉ info@gtllights.com

## Dimensions:

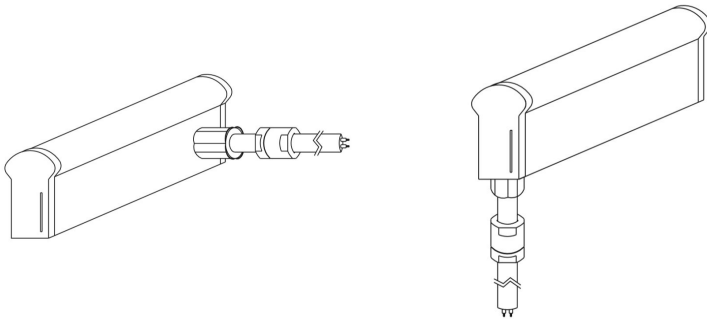
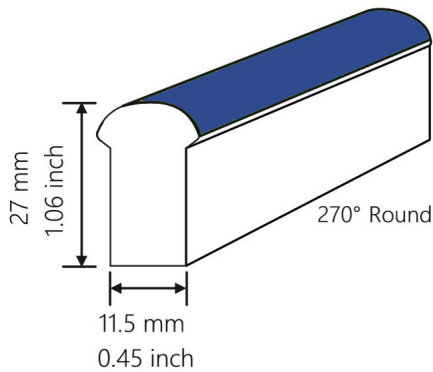

## Under Water



## Specifications:

- ✓ **Body construction:**  
PVC
- ✓ **Power per meter:**  
9W-15W
- ✓ **Voltage:**  
12V/24V/36V DC
- ✓ **Color:**  
RGB, RGBW
- ✓ **Control:**  
DMX512
- ✓ **Ingress Protection:**  
IP 68: Protected from immersion in water with a depth of more than 1 meter
- ✓ **Beam Angle:**  
120°-270°
- ✓ **Operating temperature range:**  
-13°F to 131°F (-25°C to 55°C)
- ✓ **LED life:**  
>50,000 hours
- ✓ **Mount:**  
Aluminum channel

### ADDRESS

📍 9826 Clay Rd,  
Houston, TX 77080

### CALL US

☎ 281.741.3116

### EMAIL US

✉ info@gtllights.com